

 **TOPCON**



**SIGNATURE SERIES**

*Model OC-2100*

# SIGNATURE SERIES

Model OC-2100

## Standard Chair Features

- Fixed chair back and armrests
- Electric lift with 8"(20.3cm) stroke
- Foot pedal control
- Charcoal grey or black upholstery

## Optional Features

- 15° tilt mechanism and footrest
- Locking rotation
- Sliding armrest
- Fixed headrest
- Footrest

## Chair Dimensions and Specifications

### Movements

Elevation Stroke: 8"(20.3cm)

### Electrical

115 V, 60 Hz, 5 A

220 V, 50 Hz, 3 A

### Weight

Chair Capacity: 350 lbs.(158.8kg)

Shipping Wt: 193 lbs.(87.5kg)

ETL Listed—Complies with UL and CSA Specifications

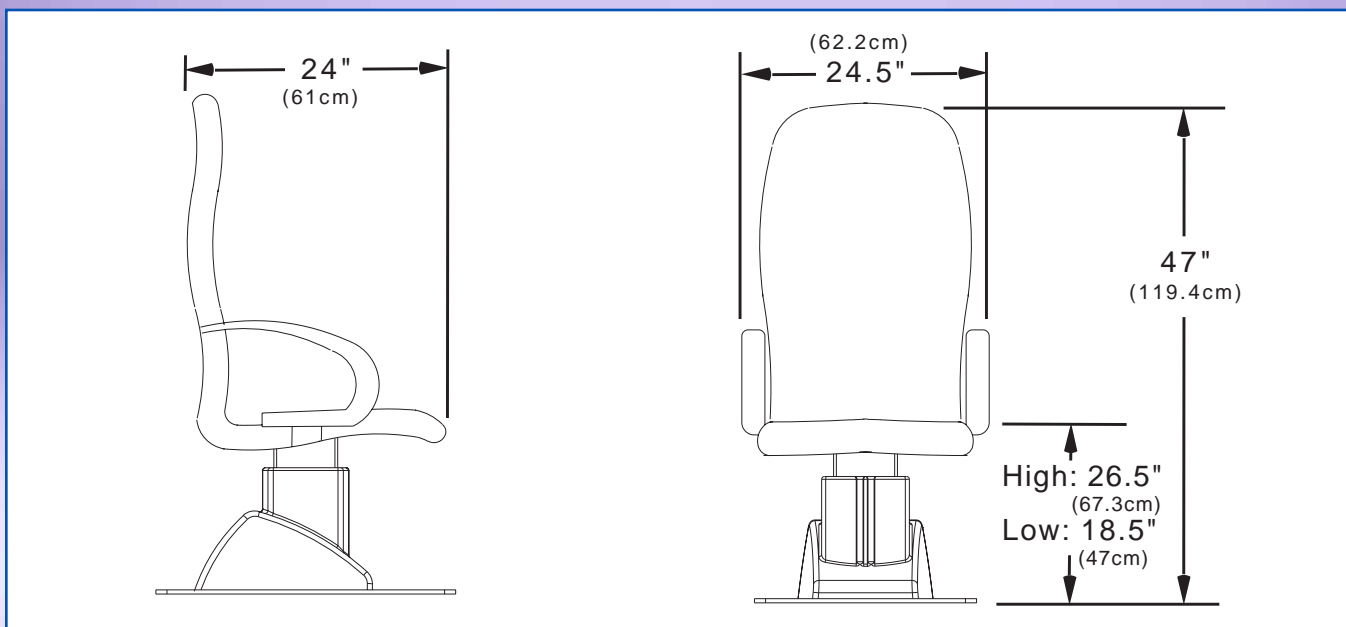

Dimensions and specifications are approximate and are subject to change without notice.

