

 **TOPCON**



**SIGNATURE SERIES**

*Model OC-2200*

# SIGNATURE SERIES

Model OC-2200

## Standard Chair Features

- Manual recline with incorporated, ambidextrous handle
- Hydraulic low lift 9"(22.9cm) stroke with a maximum seat height of 29"(73.7cm) or hydraulic high lift 12.5"(31.8cm) stroke with a maximum seat height of 35"(88.9cm)
- Illuminated membrane switch control
- Solid cast aluminum frame, armrest, footrest, and base
- Single button folding armrests
- Multi-position full range articulating headrest
- Securely locking hand brake with handle
- Ergonomically contoured cushions with anti-viral upholstery
- Self-lubricating hinges and bushings
- Choice of upholstery colors

## Optional Features

- Foot pedal control
- Single hand articulating headrest

## Chair Dimensions and Specifications

### Movements

Elevation Stroke: 12.5"(31.8cm)/9"(22.9cm)

Rotation Angle: 355°

ETL Listed—Complies with UL and CSA Specifications

### Electrical

115 V, 60 Hz, 5 A

220 V, 50 Hz, 3 A

### Weight

Chair Lift Capacity: 500 lbs. (226.8kg)

Shipping Wt: 281 lbs. (127.5kg)

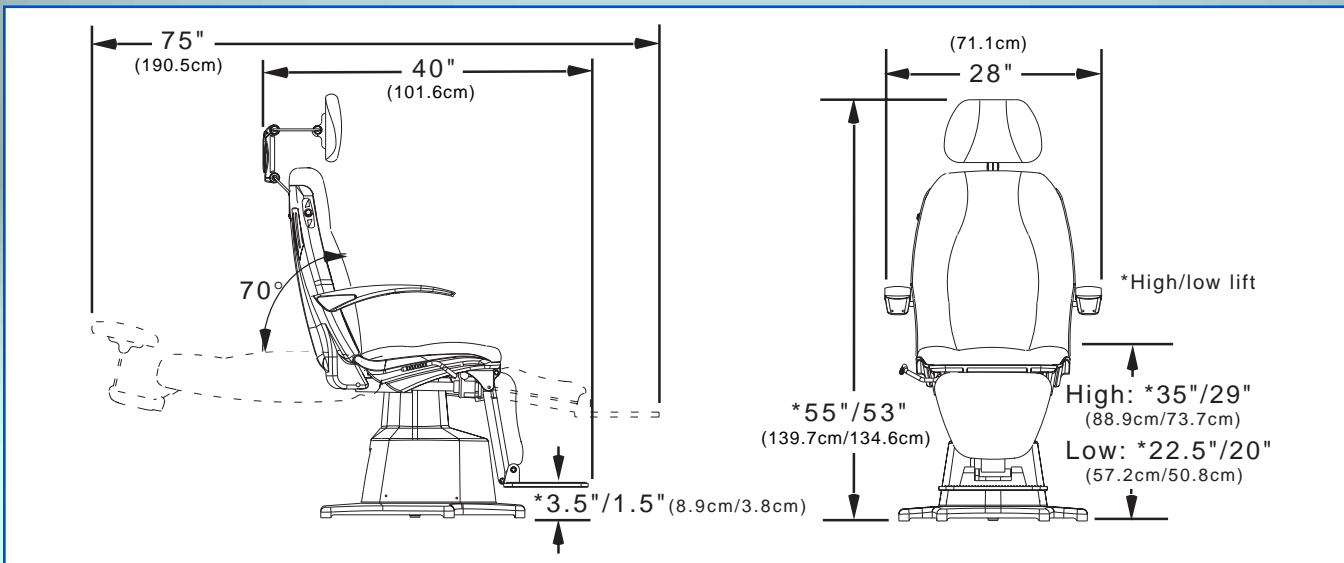

Dimensions and specifications are approximate and are subject to change without notice.

